

Orifice inserts type EB

Operating pressure $p_{max} = 500 \text{ bar}$
 Flow $Q_{max} = 120 \text{ lpm}$

1. General

Orifices are the most simple version of a flow valve, which are designed to influence mainly the flow (acc. to DIN ISO 1219-1). The employed effect is based on the physical flow law $\Delta p = (a Q)^m$. With usually $m = 2$ for sharp edged, viscosity effect minimizing, orifices. The calculation constant a copes for shape related back pressure constants as well as conversion factors for the differing dimensions; Δp (bar) and Q (lpm). This figure is evaluated best via tests (Δp - Q -curves).

These orifices are mainly employed to restrict the flow during shifting operations (e.g. increased shifting time, protection of pilot valve from excessive flow, in accumulator circuits, prevention of undesired side effects of shifting operations at directional valves with negative overlap etc.), see also D 7300. They are usually installed in hydraulic valves intended for manifold mounting. The throttle dimensions exactly fit in the port P of directional seated valves acc. to D 7300.

Symbol, mounting position

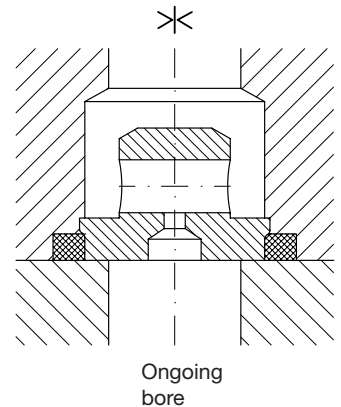

2. Available versions, main data

Order example:

EB 2 -1,7

Orifice insert	Pressure p_{max} (bar)	Flow Q_{max} (lpm)	Orifice \varnothing (mm)											
			- 0,4	- 0,6	- 0,8	- 1,0	- 1,2	- 1,7	- 2,1	- 2,5	- 3,0	- 3,5	- 4,0	- 4,2
EB 0	500	6		●	●	●	●							
EB 1	700	10	●	●	●	●								
EB 2	700	40					●	●	●					
EB 3	500	100								●		●		●
EB 4	500	120									●		●	

Nomenclature
 Installed position
 Mass (weight)

Orifice insert	
Any	
Type	EB 0 EB 1 EB 2 EB 3 EB 4
	2 g 4 g 6 g 10 g 18 g

Pressure fluid

Hydraulic oil acc. to DIN 51524 table 1 to 3; ISO VG 10 to 68 conf. DIN 51 519
 Viscosity range: min. approx. 4; max. approx. 1500 mm²/sec; Optimum: 10 to 500 mm²/sec
 Also suitable are biologically degradable pressure fluids type HEES (synth. Ester) at operation temperatures up to approx. +70°C.

Temperatures

Ambient: approx. -40...+80°C; Fluid: -25...+80°C, pay attention to the viscosity range!
 Start temperature down to -40°C are allowable (Pay attention to the viscosity range during start!), as long as the operation temperature during subsequent running is at least 20K higher. Biological degradable pressure fluids: Pay attention to manufacturer's information. With regard to the compatibility with sealing materials do not exceed +70°C.

Δp - Q -curve

Oil viscosity during the test approx. 60 mm²/sec

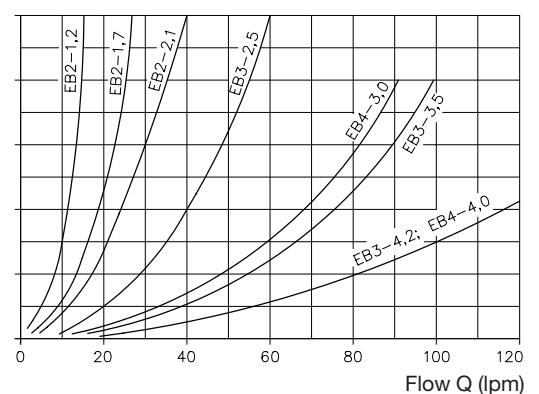
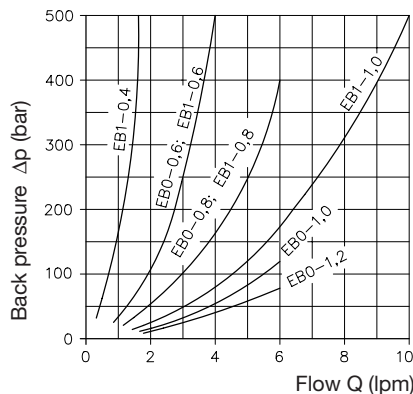

3. Unit dimensions, mounting holes

All dimensions in mm, subject to change without notice!

Type EB 0-...

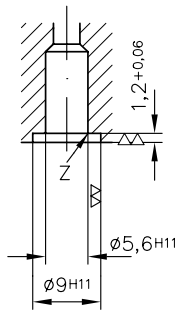

Ongoing bore
Ø3,5

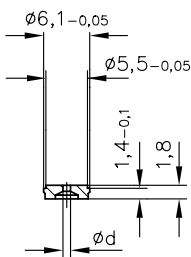

O-ring 6x1.5
NBR 90 Sh



Type EB 1-...

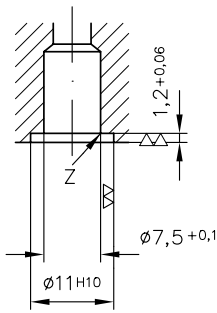

Ongoing bore
Ø4,5

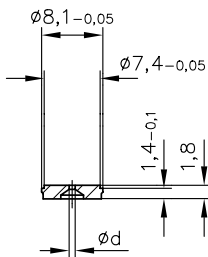

O-ring 8x1.5
NBR 90 Sh



Type EB 2-...

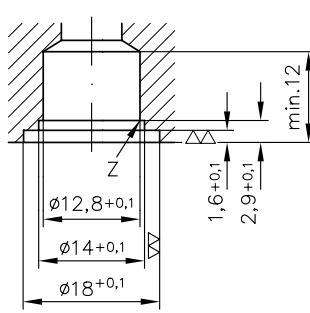

Ongoing bore
Ø10

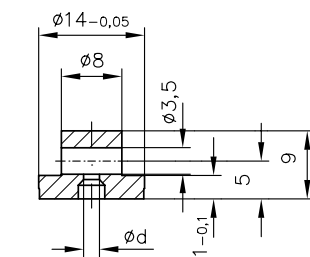

O-ring 14x2
NBR 90 Sh

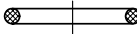

Type EB 3-...

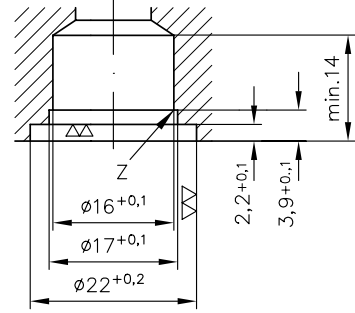

Ongoing bore
Ø14

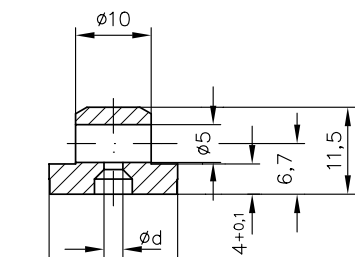

O-ring 17.12x2.62
NBR 90 Sh

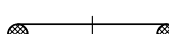

Type EB 4-...

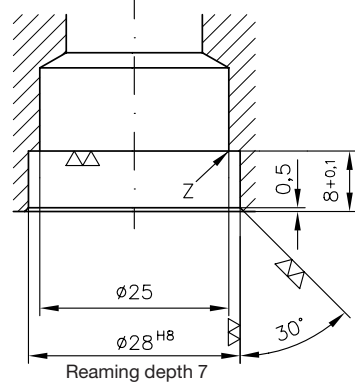

Ongoing bore Ø20

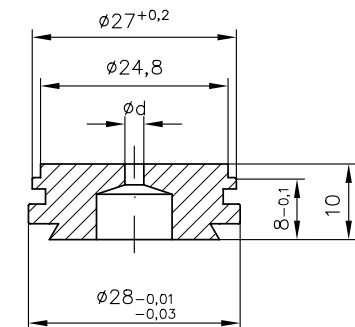

O-rings 23.47x2.62
NBR 90 Sh



Z = Sharp edged but deburred, all other bores with chamfer 0.2 mm
Ød = Orifice (sect. 2)

Attention: O-rings are not scope of delivery and have to be ordered additionally !

Notes regarding installation:

The exact fixation of the orifice insert in the housing takes place by plastic deformation of the surrounding material at the marked annular section during tightening of the mounting screws. This procedure makes housing bodies made of material with yield ability necessary i.e. all usual materials for hydraulic valves is fine excluding hardened or other material with extreme strength.

