

Characteristics

Pilot Operated Servo Proportional DC Valve Series D*1FP

The series of pilot operated servo proportional valves D*1FP transfers the advantages of the Parker patented Voice Coil Drive (VCD®) to larger frame sizes and thus high flow rates. The high dynamics / high precision drive of the pilot valve allows the optimum control of the main spool and results in servo class performance of the complete valves.

The D*1FP series is available in 5 sizes:

D31FP NG10 (CETOP05)

D41FP NG16 (CETOP07)

D81FP NG25 (CETOP08) for port diam. up to 26 mm

D91FP NG25 (CETOP08) for port diam. up to 32 mm

D111FP NG32 (CETOP10)

The safety concept works with a safe 4th position at the D1FP pilot valve. This ensures that the main stage is hydraulically balanced at power down and allows to have the main spool spring centered (for overlapped spools) or approximately 10% spring offset to spool position A or B (for zerolap spools).

The innovative integrated regenerative function into the A-line (optional) allows new energy saving circuits for differential cylinders. The hybrid version can be switched between regenerative mode and standard mode at any time.

Technical features

- High dynamics
- High flow
- Defined spool positioning at power-down - optional P-A/B-T or P-B/A-T or center position (for overlapped spools)
- Onboard electronics
- **NEW:** Energy saving A-regeneration
- **NEW:** Switchable hybrid version

D41FPE52 (Standard)

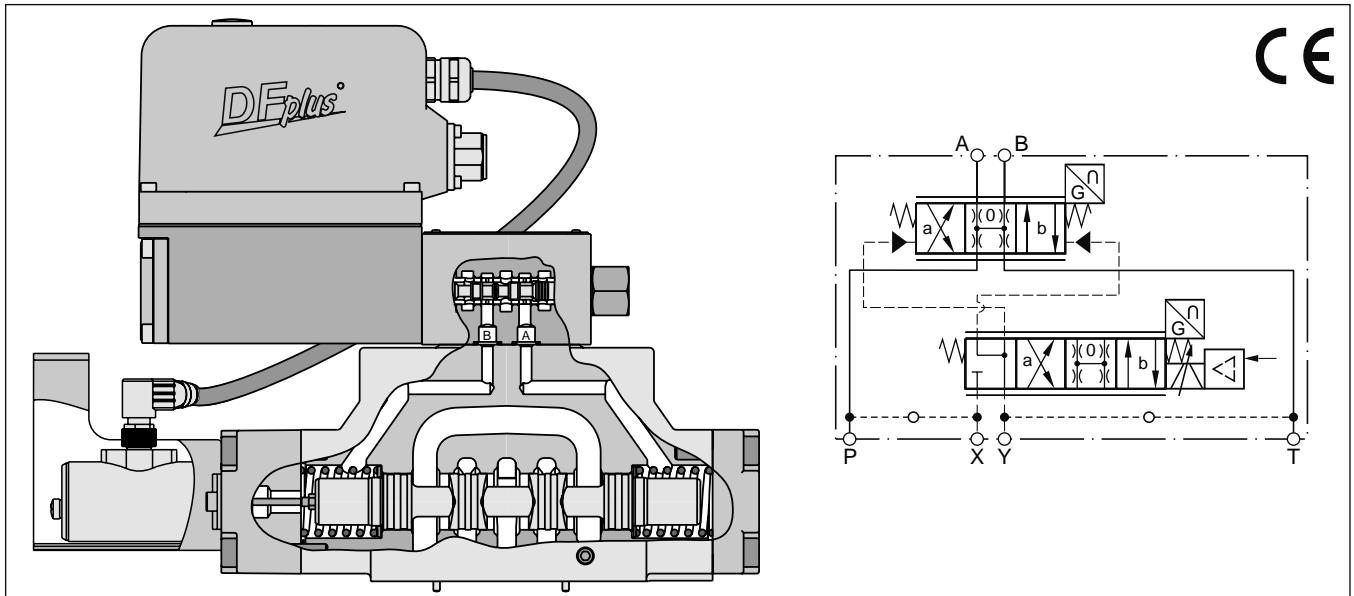

D_1FP UK.INDD RH 17.08.2011



D41FP Standard

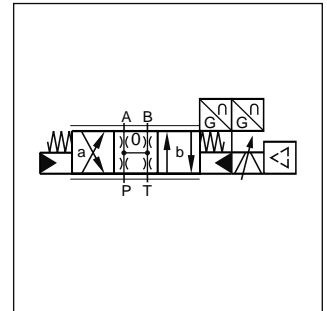

Standard D*1FPE

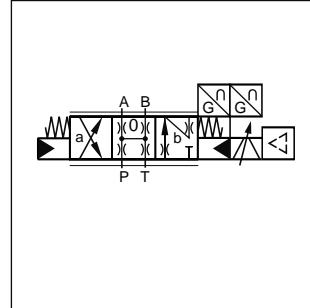

NEW: A-regeneration D*1FPR

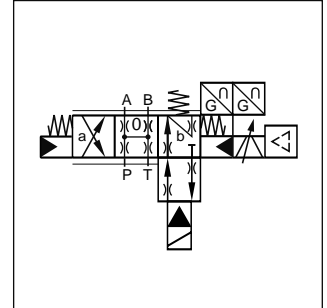

NEW: Hybrid D*1FPZ

Further literature about the opportunities of energy savings and more functional details of the integrated regeneration is available on request.

D*1FPR and D*1FPZ

3

Regenerative valve D*1FPR

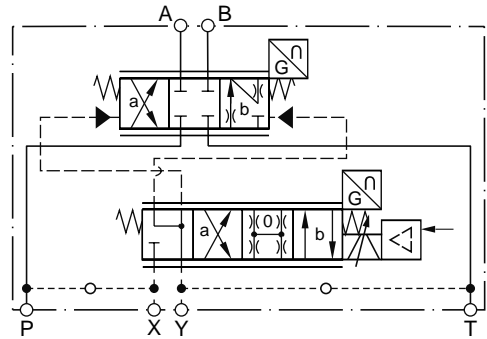
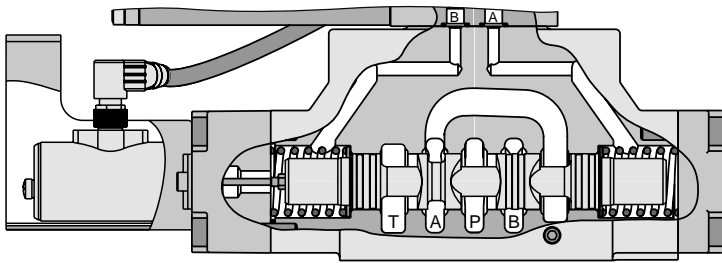

Hybrid valve D*1FPZ

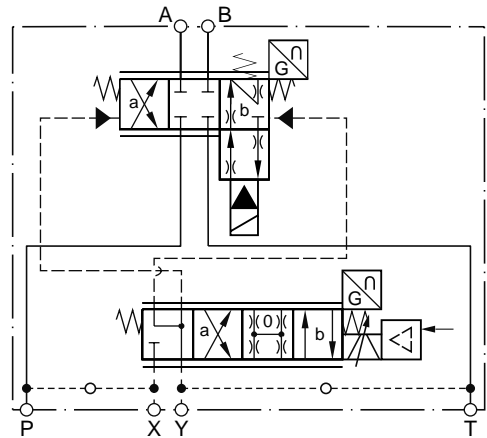
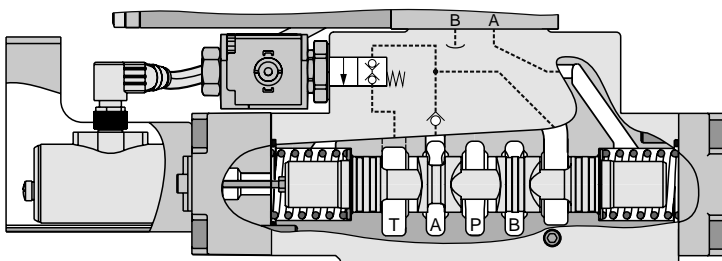

**D*1FPR (regenerative valve)
 Cylinder extending**

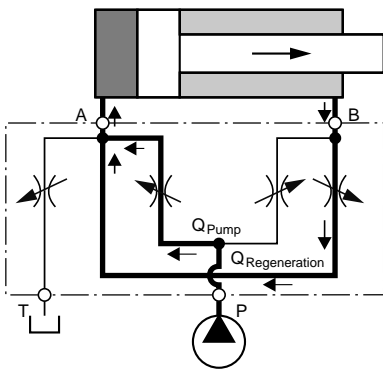

**D*1FPZ (hybrid valve)
 Cylinder extending
 in regenerative mode (high speed)**

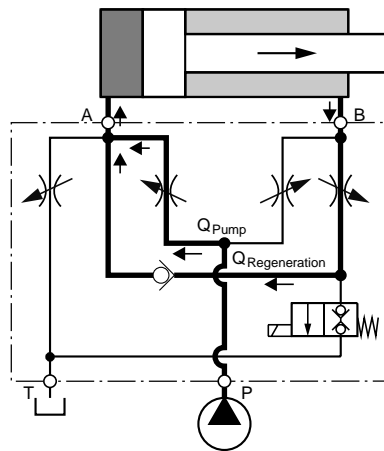

**Cylinder extending
 in standard mode (high force)**

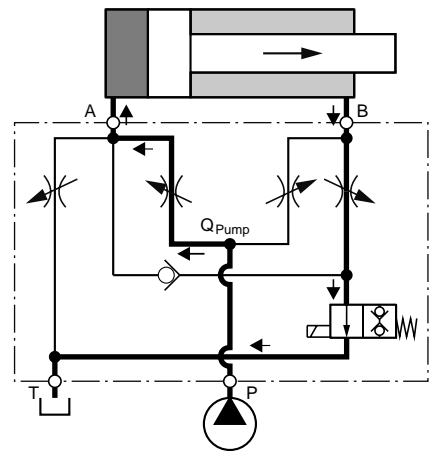

Flow rate in % of nominal flow

Size ¹⁾	Spool	Port					
		A-T	P-A	P-B	B-A (R-Valve)	B-A (Hybrid)	B-T (Hybrid)
D41FPR/Z	31/32/61	100%	50%	100%	50%	40%	20%
D91FPR/Z	31/32/61	100%	50%	100%	50%	50%	25%
D111FPR/Z	31/32/61	on request					

¹⁾ D31FP: For size NG10 please refer solution with sandwich- and adaptor plates "H10-1666L / H10-1662 / A10-1664 / A10-1665L" in chapter 12.
 D_1FP UK.INDD RH 17.08.2011

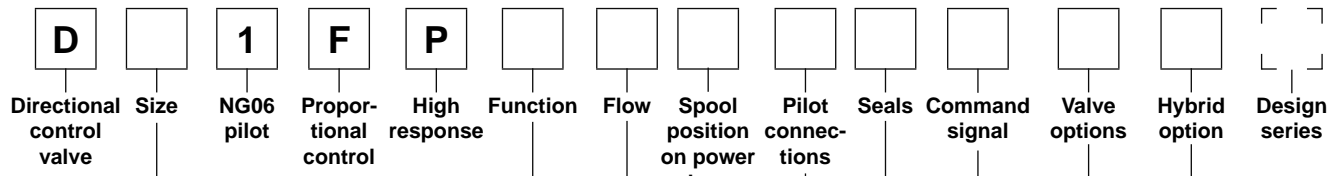

Code	Size
3	NG10 / CETOP05
4	NG16 / CETOP07
8	NG25 / CETOP08
9 ¹⁾	NG25 / CETOP08
11	NG32 / CETOP10

¹⁾ for enlarged connections
 Ø 32 mm

Code	Hybrid option
0	Standard for spool code B, E, R
L ⁷⁾	Hybrid valve 24V normally closed for spool code Z

⁷⁾ see page "Regenerative and hybrid function" (not for D31FP)

Code	Valve options
0	6+PE acc. EN175201-804
5	11+PE acc. EN175201-804
7	6+PE + Enable

Code	Signal	Function
B	0...±10V	0...+10V P -> B
E	0...±20mA	0...+20mA P -> B
K	0...±10V	0...+10V P -> A
S	4...20mA	12...20mA P -> A

Code	Seals
N	NBR
V	FPM
H	for HFC fluid

Code	Inlet	Drain
1	internal	external
2	external	external
4	internal	internal
5	external	internal

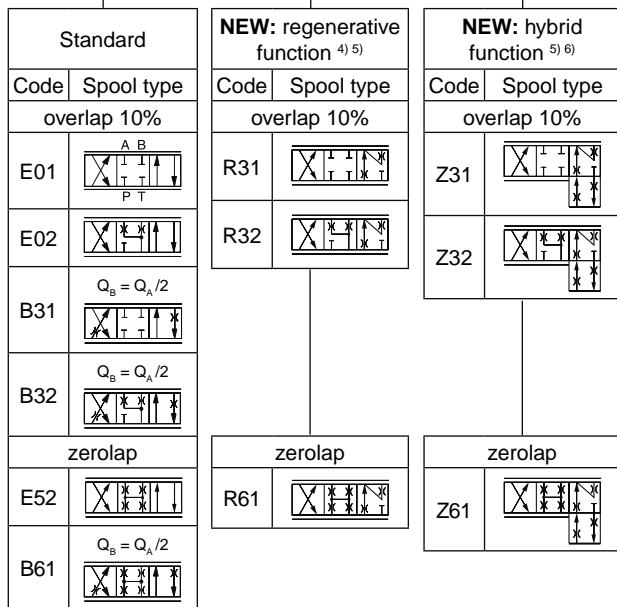

Code	Flow [l/min]				
	at Δp = 5bar per metering edge				
	D31	D41	D81	D91	D111
D	90	—	—	—	—
E	120	—	—	—	—
F	—	200	—	—	—
H	—	—	400	450	—
L	—	—	—	—	1000

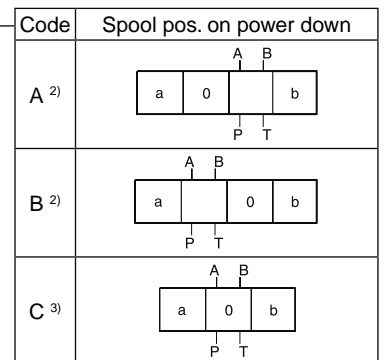

- ²⁾ approx. 10% opening, only zero lapped spools.
 - ³⁾ for overlapped spools.
 - ⁴⁾ not for size code 8.
 - ⁵⁾ for regenerative and hybrid function at code 3 (NG10) please refer to solutions with sandwich and adaptor plates "H10-1666L / H10-1662 / A10-1664 / A10-1665L" in chapter 12.
- D31FP spooltype: R31 R32 R61
- ⁶⁾ nor for valve D31FP and D81FP

Please order connector separately.

General			
Design	Servo Proportional directional control valve, pilot operated		
Actuation	VCD®-actuator		
Size	NG10 (CETOP 05)	NG16 (CETOP 07)	NG25 (CETOP 08) / NG32 (CETOP 10)
	D31	D41	D81 / D91 / D111
Mounting Interface	DIN 24340 / ISO 4401 / CETOP RP121 / NFPA		
Mounting position	unrestricted		
Ambient temperature	[°C]	-20...+60	
MTTF _D value	[years]	50	
Weight	[kg]	11.3	14.2 / 23.5 / 64.5
Vibration resistance	[g]	10 Sinus 5...2000 Hz acc. IEC 68-2-6 30 Random noise 20...2000 Hz acc. IEC 68-2-36 15 Shock acc. IEC 68-2-27	
Hydraulic			
Max. operating pressure	[bar]	Internal Pilot Drain P, A, B, X 350; T, Y 35 External Pilot Drain P, A, B, T, X 350; Y 35	
Fluid	Hydraulic oil acc. DIN 51524...535, other on request		
Fluid temperature	[°C]	-20...+60	
Viscosity permitted	[cSt] / [mm ² /s]	20...380	
Viscosity recommended	[cSt] / [mm ² /s]	30...80	
Filtration	ISO 4406 (1999) 18/16/13 (meet NAS 1638: 7)		
Nominal flow at Δp = 5 bar per control edge ¹⁾	[l/min]	120	200 / 400 / 450 / 1000
Max. recommended Flow (Standard)	[l/min]	250	600 / 1000 / 3000
Regenerative B-A / B-T	depending on application, see flow curves		
Leakage at 100 bar			
Overlapped spool	[ml/min]	200	200 / 600 / 1000
Zerolapped spool	[ml/min]	900	900 / 1000 / 5000
Pilot	[ml/min]	< 1000	
Pilot supply pressure	[bar]	20...350	
Pilot flow during step response at 210 bar	[l/min]	10	12 / 24 / 40
Static / Dynamic			
Step response at 100% stroke ²⁾	[ms]	10	13 / 19 / 45
Frequency response			
Amplitude ±5 % at 210 bar	[Hz]	128	95 / 95 / 40
Phase ±5 % at 210 bar	[Hz]	118	95 / 90 / 75
Hysteresis	[%]	< 0.1	
Sensitivity	[%]	< 0.05	
Temperature drift of Center Position	[%/K]	< 0.025	
Electrical			
Duty ratio	[%]	100	
Protection class	IP65 in accordance with EN 60529 (with correctly mounted plug-in connector)		
Supply voltage / ripple	[V]	22...30, ripple < 5% eff., surge free	
Current consumption max.	[A]	3.5	
Pre-fusing	[A]	4.0 A medium lag	
Input signal Code K (B)	voltage [V]	+10...0...-10, ripple < 0.01 % eff., surge free, 0...+10V P->A (P->B)	
	Impedance [kOhm]	100	
Code E	voltage [mA]	+20...0...-20, ripple < 0.01 % eff., surge free, 0...+20mA P->B	
	Impedance [Ohm]	250	
Code S	current [mA]	4...12...20, ripple < 0.01 % eff., surge free, 12...20 mA P->A	
	Impedance [Ohm]	250	
	< 3.6 mA = enable off, > 3.8 mA = enable on acc. NAMUR NE43		
Input Capacitance typ.	[nF]	1	
Differential input max.	[V]	Code 0: 30 for terminal D and E against PE (terminal G) 11 for terminal D and E against 0V (terminal B)	
	[V]	Code 5: 30 for terminal 4 and 5 against PE (terminal 1) 11 for terminal 4 and 5 against 0V (terminal 2)	
	[V]	Code 7: 30 for terminal D and E against PE (terminal G)	
Enable signal	[V]	Code 5/7: 5...30, Ri = 9 kOhm	
Diagnostic signal	[V]	+10...0...-10 / +Ub, rated max. 5 mA	
EMC	EN 61000-6-2, EN 61000-6-4		
Electrical connection	Code 0/7	6 + PE acc. EN 175201-804	
	Code 5	11 + PE acc. EN 175201-804	
Wiring min.	Code 0/7 [mm ²]	7 x 1.0 (AWG16) overall braid shield	
	Code 5 [mm ²]	8 x 1.0 (AWG16) overall braid shield	
Wiring lenght max.	[m]	50	

¹⁾ Flow rate for different Δp per control edge:

²⁾ Measured with load (210 bar pressure drop/two control edges)

$$Q_x = Q_{Nom.} \cdot \sqrt{\frac{\Delta p_x}{\Delta p_{Nom.}}}$$

Electrical characteristics hybrid option

Duty ratio		100%		
Protection class		IP 65 in accordance with EN 60529 (with correctly mounted plug-in connector)		
		D41	D91	D111
Supply voltage	[V]	24	24	24
Tolerance supply voltage	[%]	±10	±10	±10
Current consumption	[A]	1.21	0.96	1.29
Power consumption	[W]	29	23	31
Solenoid connection		Connector as per EN 175301-803		
Wiring min.	[mm ²]	3 x 1.5 recommended		
Wiring length max.	[m]	50 recommended		

With electrical connections the protective conductor (PE ⚡) must be connected according to the relevant regulations.

3

Wiring

Code 0, 6 + PE acc. EN 175201-804

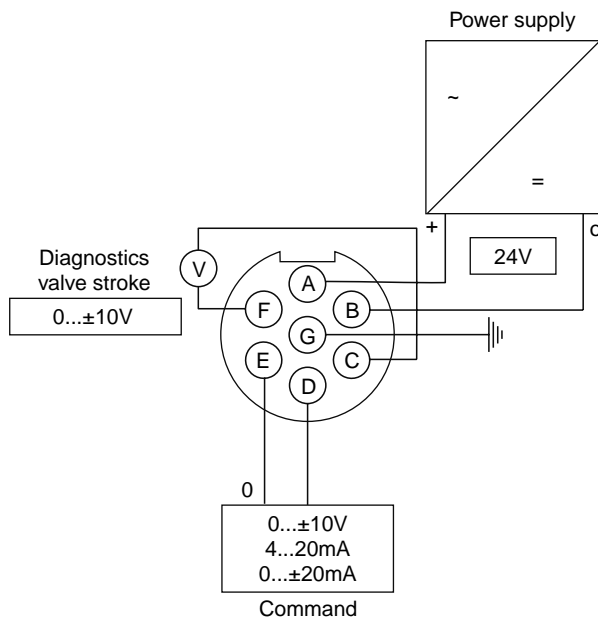

Code 5, 11 + PE acc. EN 175201-804

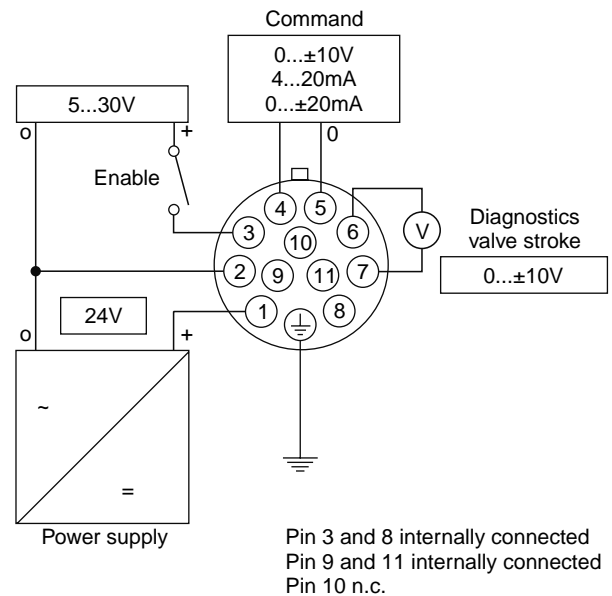

Code 7, 6 + PE acc. EN 175201-804 + enable

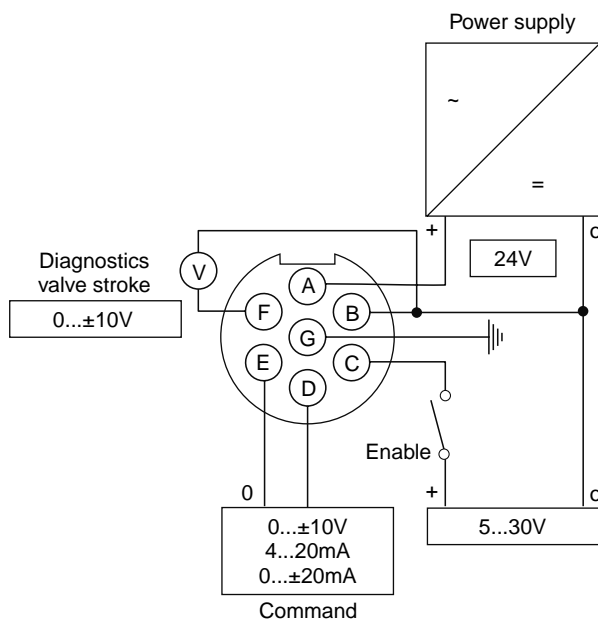

Frequency response

±5 % / ±25 % / ±90 % command signal
 Dynamics at 210 bar pilot supply pressure

D31FP

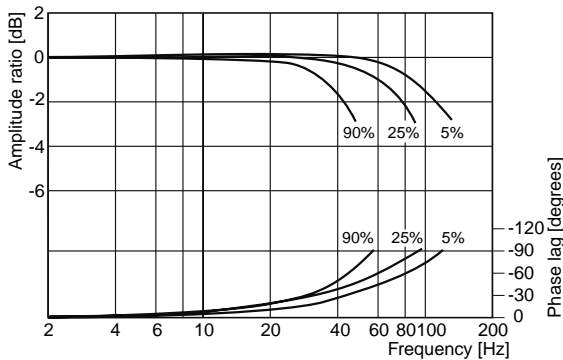

D41FP

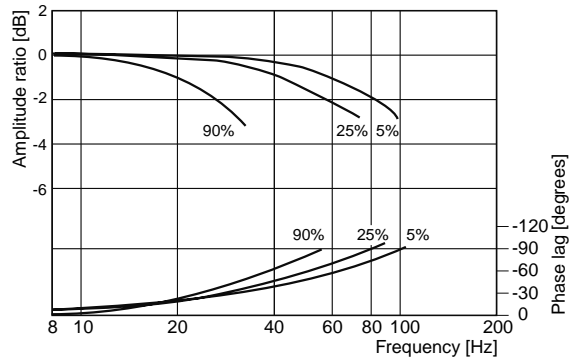

D81/91FP

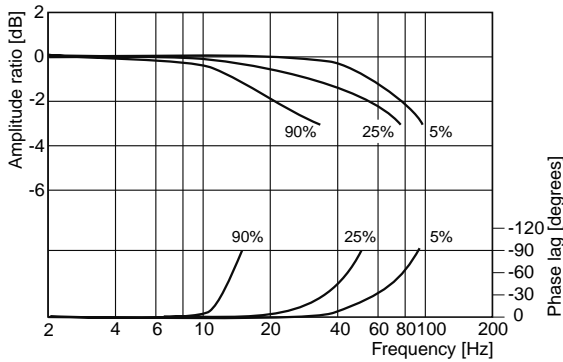

D111FP

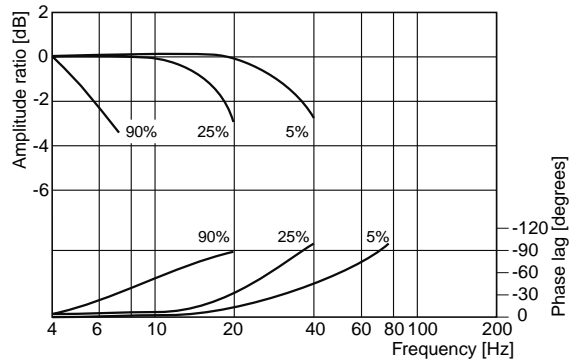

D*1FPB/E flow curves

at $\Delta p = 5$ bar per metering edge

D31FP

spool type E01/02/52, B31/32/61

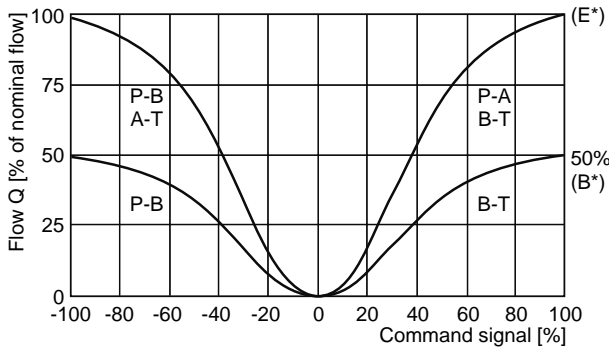

D41FP

spool type E01/02/52, B31/32/61

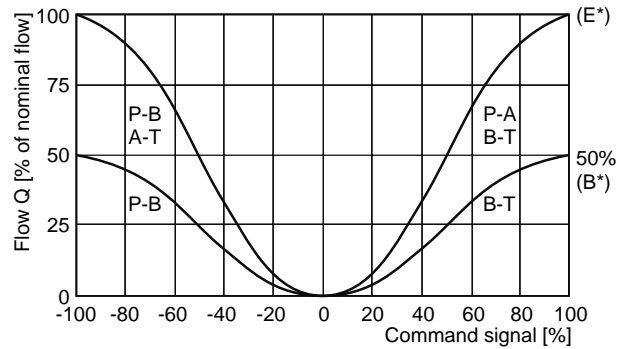

Flow curves

D81/91FP

Spool type E01/02/52, B31/32/61

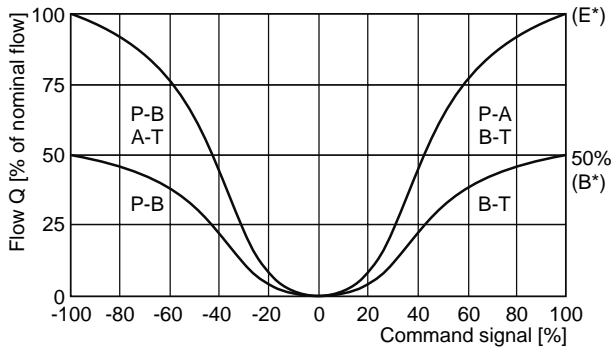

D111FP

Spool type E01/02/52, B31/32/61

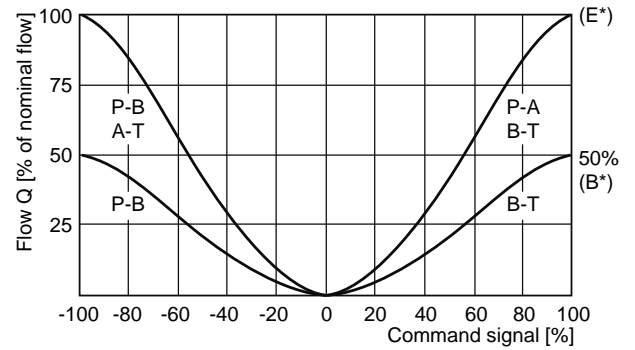

D*1FPR/Z flow curves

at $\Delta p = 5$ bar per metering edge

D31FP

Spool type R31/32/61

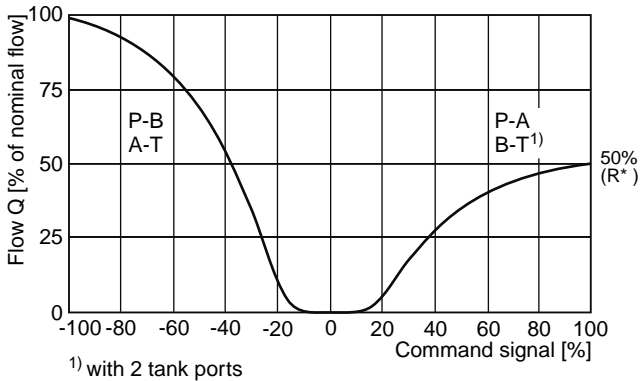

D41FP

Spool type R/Z 31/32/61

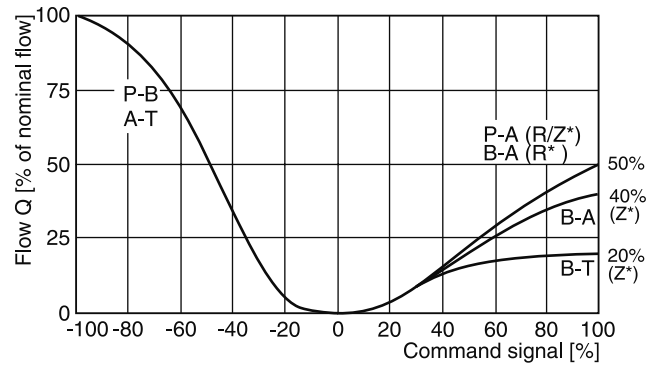

D91FP spool type R/Z 31/32/61

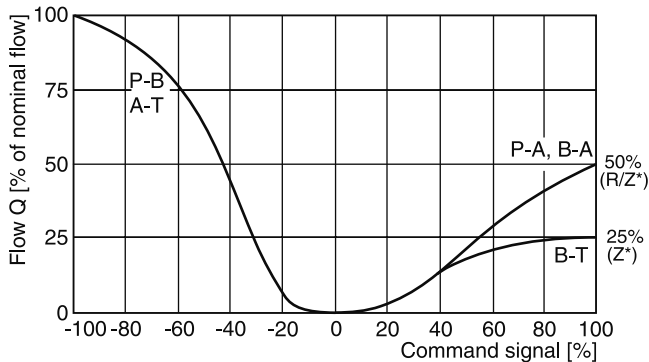

D111FP

spool type R/Z* on request

Detail: Standard, regenerative and hybrid flow curves

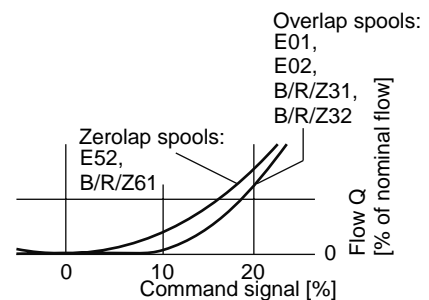

Pilot oil inlet (supply) and outlet (drain)

○ open, ● closed

Pilot oil		B	C
Inlet	Drain		
internal	external	○	●
external	external	●	●
internal	internal	○	○
external	internal	●	○

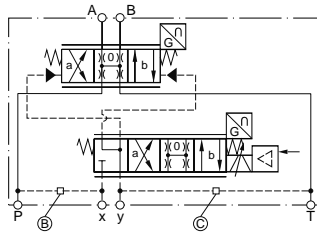

3

D31FPB/E

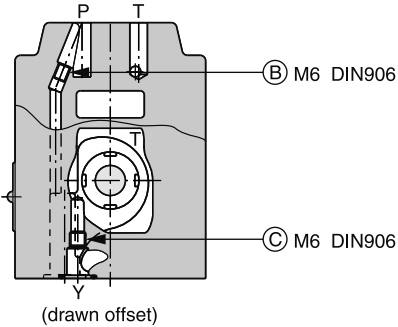

D31FPR

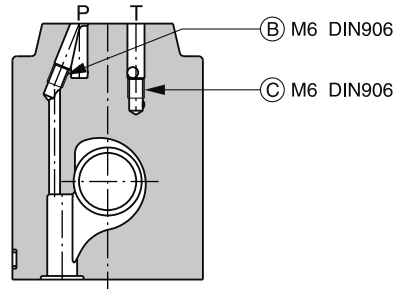

D41FPB/E

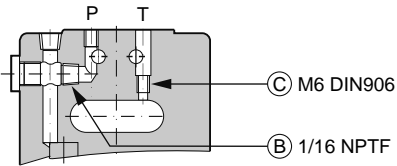

D41FPR

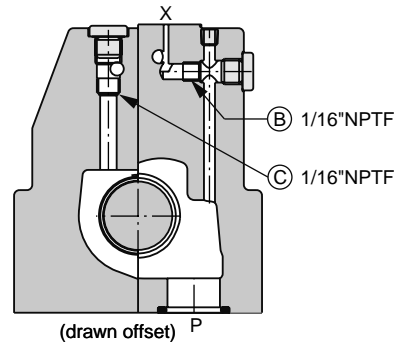

D41FPZ

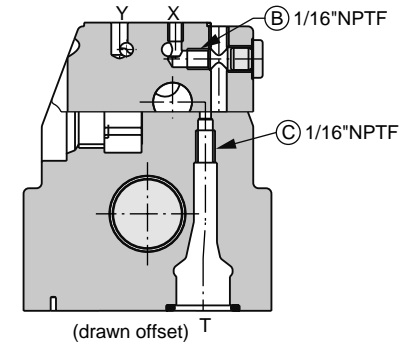

D91FPB/E

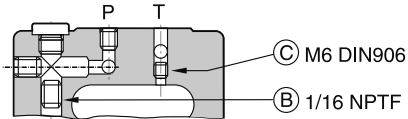

D91FPR

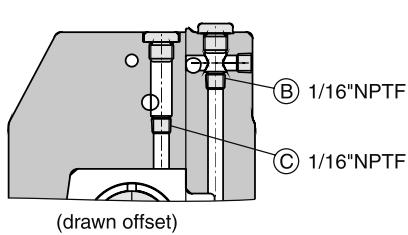

D91FPZ

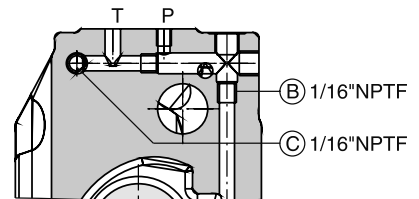

D111FPB/E

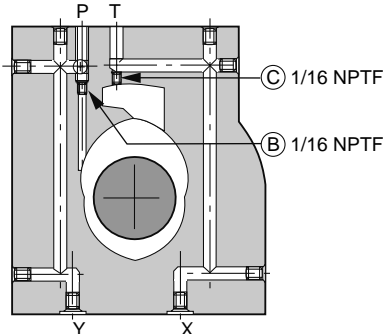

D111FPR

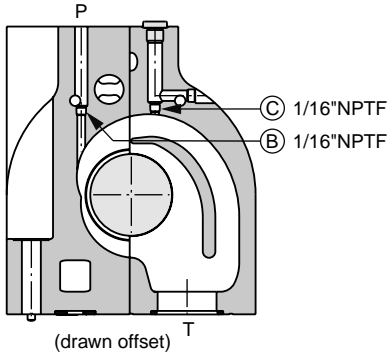

D111FPZ

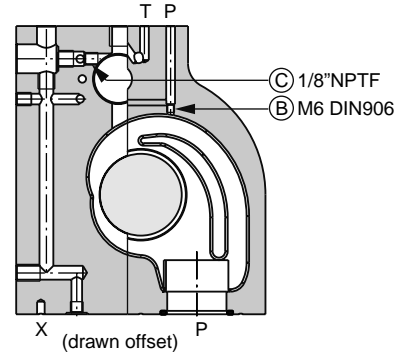

D_1FP_UK.INDD RH 17.08.2011

Dimensions

D31FP

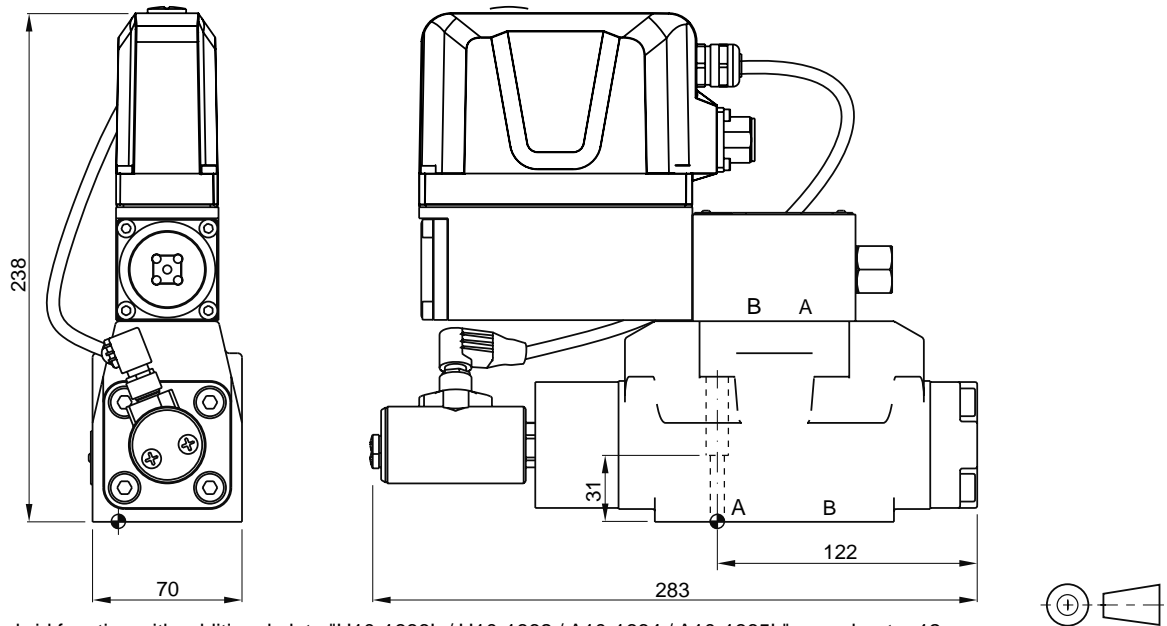

Regenerative and hybrid function with additional plate "H10-1666L / H10-1662 / A10-1664 / A10-1665L", see chapter 12.

Surface finish	Kit			Kit
	BK385	4x M6x40 DIN 912 12.9	13.2 Nm ±15%	NBR: SK-D31FP FPM: SK-D31FP-V

D41FP

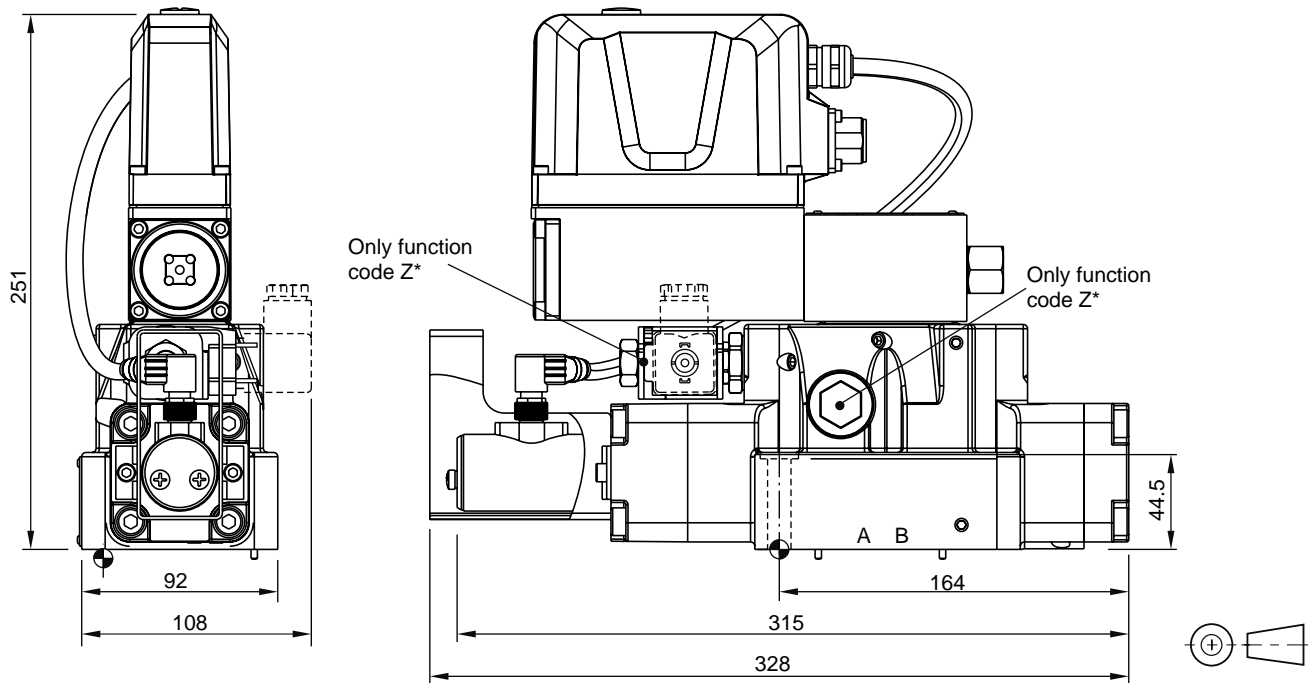

Surface finish	Kit			Kit
	BK320	2x M6x55 4x M10x60 DIN 912 12.9	13.2 Nm ±15% 63 Nm ±15%	NBR: SK-D41FP FPM: SK-D41FP-V

D81/91FP

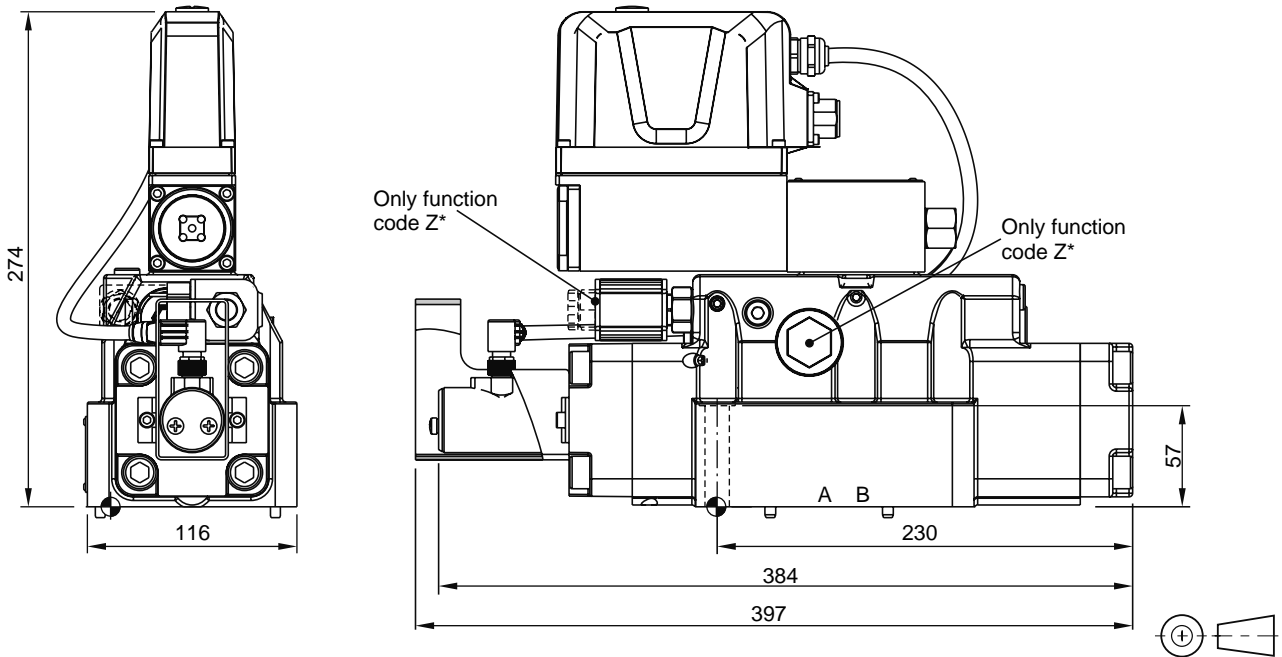

Surface finish	Kit	Kit	Kit	Kit
	BK360	6x M12x75 DIN 912 12.9	108 Nm ±15%	NBR: SK-D81/D91FP FPM: SK-D81/D91FP-V

D111FP

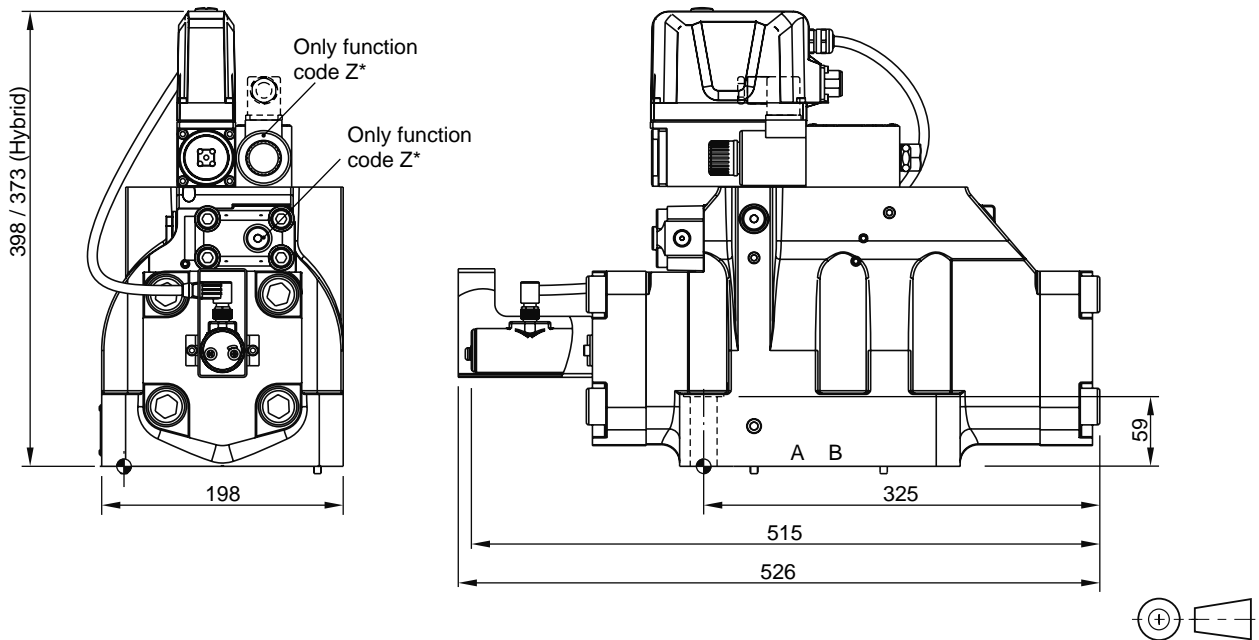

Surface finish	Kit	Kit	Kit	Kit
	BK386	6x M20x90 DIN 912 12.9	517 Nm ±15%	NBR: SK-D111FP FPM: SK-D111FP-V